

ROTARY VANE DEEP VACUUM PUMPS



90060 1.5 CFM VACUUM PUMP (TWO STAGE)

This lightweight and easy to store vacuum pump (12 lbs.) is ideal for less than 3 lb. capacity evacuation. The inlet ports include 1/4" flare and 1/2" ACME (for automotive R134a systems).



90062 2 CFM VACUUM PUMP (SINGLE STAGE)

This model is ideal for smaller sized systems (less than 3 lb. charge capacity). The inlet ports include 1/4" flare and 1/2" ACME (for automotive R134a systems).



90065 5 CFM VACUUM PUMP (TWO STAGE)

This model is an excellent choice for small to medium sized systems (2.5 lb. to 10 lb. charge capacity). This two stage pump features a manifold valve to isolate it from the system and three inlet ports: 1/4" flare and 1/2" ACME (for automotive R134a systems).



90067 7.5 CFM VACUUM PUMP 90070 10 CFM VACUUM PUMP (TWO STAGE)

These models are the choice for medium sized and larger systems (5 lb. and above capacity). The 1/2 horsepower motor makes cold condition start-up quick and easy. These two stage pumps feature a manifold valve to isolate them from the system and three inlet ports: 1/4" flare, 3/8" flare and 1/2" ACME (for automotive R134a systems).



Mastercool[®] Inc.

98060

Electronic Vacuum Gauge

Thank you for purchasing the **98060 Vacuum Gauge**. It is an accurate instrument with special features. Please read these instructions carefully to get the best performance and many years of trouble-free service from your **New Mastercool 98060**.

OPERATING CONTROLS AND FUNCTIONS

1. ON-OFF slide switch.
2. Dual Purpose LED indicator.
 - A. Illuminates when the slide switch is on.
 - B. Hardly glows, or may not illuminate when battery is low.
3. LED lamps indicate the entire range for vacuum pump (from atmosphere down to 50 microns vacuum).
4. Carrying case.
5. Standard 1/4 inch male flare fitting.
6. Quick cap for fitting.
7. Built-in hanger.
8. Tilt-up cover for battery compartment.
9. Compartment for 9 volt battery.
10. Calibration screw.

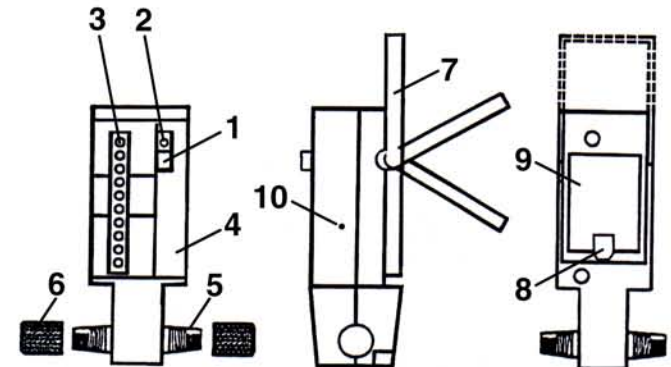

Figure 1



Mastercool[®] Inc.

One Aspen Drive, Randolph, NJ 07869-1103
Phone: (973) 252-9119, Fax: (973) 252-9119
Web-site: www.mastercool.com

OPERATION

When connecting hoses to the 98060, do not use wrenches of any kind. Use only service hose connections with a knurled fitting on the end. The hand tightened connection of a service hose is an adequate connection.

Do not use the 98060 as a series connection from the vacuum pump to the system. This will definitely cause a pressure drop. Most vacuum pumps have a fitting near the suction inlet of the pump. If you use this fitting for the 98060, there is no way to shut off the pump to see if there is a rise of vacuum in the system.

See figure (2) for typical vacuum pump connections.

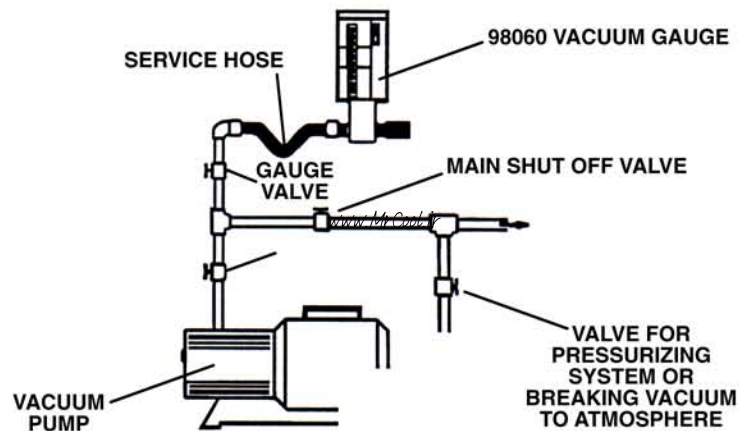

Figure 2

1. After you have connected the vacuum pump to the system, close all valves.
2. Run vacuum pump
3. Gradually open main valve and pump valve.
4. Open valve to vacuum gauge.
5. Allow 15 seconds for sensor to stabilize.

During the initial stages of evacuation, the atmosphere lamp may go out. This is normal when large volumes of air pass by the sensor. As the lamps indicate the vacuum levels in the system, two lamps may be energized at the same time. This is normal when there is a transition from one level to the next.

LOW BATTERY INDICATOR

If the LED indicator (No. 2) in Fig. (1) is not as bright as the other lamps, or doesn't light at all, the battery should be changed. (Use only Alkaline batteries).

REMINDER: Always shut off the gauge valve before you stop the vacuum pump.

SPECIFICATIONS:

SENSOR TYPE	Thermistor
VACUUM RANGE	5000 Microns
SCALE INDICATORS	LED
POWER SOURCE	9 Volt Alkaline Battery (not included)
CONTINUOUS USAGE	20 Hours (With a new battery)
LOW BATTERY INDICATOR	LED
DIMENSIONS	1-1/2" X 1-3/4" X 5-3/4"
WEIGHT	6-1/2 Oz.

CALIBRATIONS

The micron pressure readings have been calibrated at the factory. It is permanent and never needs resetting. However, due to seasonal temperature variations, you may have to make a slight ambient adjustment. The gauge is perfectly calibrated when, after you push the slide switch to ON, both the atmosphere and slide switch lamps are energized. Should the 5,000 micron lamp go on instead of the atmosphere lamp, insert a small screwdriver into the opening at the side of the case (No. 10 in Fig. 1), locate screw and make the adjustment until only the atmosphere and slide switch lamps go on. Do not overturn the screw, it may turn off the atmosphere light.

MAINTENANCE

The 98060 electronic vacuum gauge sensor is cleanable. It is good maintenance practice to clean the sensor periodically. Use an eyedropper to pour about 2 teaspoons of ordinary rubbing alcohol into the fitting. Cap the fitting and shake about 10 seconds, empty and air dry. (The slight movement of the fitting in the case is normal and does not affect the internal connection in any way). When transporting the 98060 as a separate unit, close both ends with the quick caps.

TROUBLESHOOTING GUIDE

Problem: Erratic Readings

Solution: The sensor is contaminated with oil vapor. Clean the sensor as described in the Maintenance section.

Problem: Atmosphere LED is dim or doesn't light.

Solution: Weak batteries. Replace with Alkaline batteries only.

Problem: 5,000 Micron LED lights instead of atmosphere LED.

Solution: Possible cause is excessive seasonal ambient temperature change. Make calibration adjustment as described in the CALIBRATION section.